



AO  
AMRAPUR  
OVERSEAS



Sourcing is our core strength! With over 50 years of sourcing experience, we bring with us a deep understanding of both the Asian manufacturing culture, as well as in-depth understanding of retail – our customers. We have offices around the world giving us a global advantage.

Expanding on our core business of home textiles, Amrapur Overseas is a leader in development of products across several areas. Our main markets are North America, Mexico, Central and South America, and we are also working currently with customers in Europe, South Africa the Middle-East and Asia markets.



- **Headquarters- USA**  
1560 East 6th Street, Corona, CA 92879, US  
info@amrapur.com • +1 714-893-8808
- **Showroom - NYC**  
306, 5th Ave, 4th Floor, New York, NY, 10001
- **Hong Kong**  
Harbour Crystal Centre, 100 Granville Road,  
Tsim Sha Tsui East, Kowloon, Hong Kong
- **India**  
Tirupur
- **Bangladesh**  
Baridhara, Dhaka
- **China**  
Guangzhou and Nantong



We operate in our new state-of-the-art 225,000 square foot facility in Southern California. We have invested in the latest software and space saving racking & sortation systems, allowing us to pick and pack goods while successfully handling large number of SKUs with low overhead.

With expert capability we can drop ship within 24 hours for our retail partners. Our staff is fully equipped with EDI experts, retail projections & planning team and a dedicated sales team for each and every retail partner.

We commit our time, expertise and financial strength to grow and help support our retail relationships.



# COVID-19 Impact

With the current situation, we have included PPE as a part of our business . Given our experience with sourcing, we've successfully sourced and sold many categories of PPE, including Gloves, Masks, Anti-bacterial Wipes, and Medical Gowns.

In addition, most of our products are FDA certified and compliant with US regulatory standards. Furthermore, to obtain better freight costs, we are partnering with factories based in Thailand, Malaysia, and India and other Asian countries.



# Factory Details

Production



Shipment QC



Warehouse



# DISPOSABLE NITRILE GLOVES



## PRODUCT SPECIFICATIONS:

- Nitrile gloves are designed for medical-related services, food handling, parts handling, janitorial services, etc.
- Disposable for easy use and clean up
- Puncture-resistant nitrile keeps your hands safe from chemicals
- Single use/Fits either hand
- 4 Sizes available: Small, Medium Large, X-Large

**FOB Corona**

**Medical Grade  
Box of 100**

**Industrial Grade  
Box of 100**

**\$12.00**

**\$10.50**

## USE SPECIFICATIONS:

Case Contents: 50 pairs (100 total); 50/inner carton, 1000 pcs/carton

Case Dimension: (L)35" x (W)26" x26" cm

Case Weight: 5 kg

# KN95 MASK



## PRODUCT SPECIFICATIONS:

- Cleared by the U.S. Food and Drug Administration
- Reduces wearer's exposure to particles including small particle aerosols and large droplets
- Tight-fitting
- Filters out at least 95% of airborne particles including large and small particles
- When properly fitted and donned, minimal leakage occurs around edges of respirator when user inhales

## USE SPECIFICATIONS:

Case Contents: 150 pieces/inner carton, 3600 pcs/carton  
Case Dimension: 30" x 17" x 20"  
Case Weight: 44 lbs

**FOB Corona**

**\$1.05**

**Quantity**

**28,950**

# TM MEDICAL SURGICAL MASK (Level 2)



## PRODUCT SPECIFICATIONS:

- Cleared by the U.S. Food and Drug Administration
- Fluid resistant and provides the wearer protection against large droplets, splashes, or sprays of bodily or other hazardous fluids. Protects the patient from the wearer's respiratory emissions
- Loose-fitting
- Disposable

Price

Quantity Available

FOB Corona

\$0.40c

10,700

## CASE SPECIFICATIONS:

Case Contents: 20 pieces per box, 6000 pcs/  
carton

Case Dimension: 27.5" x 16.14" x 22.83"

Case Weight: 50.71lbs



# THREE-LAYER PROTECTIVE MASK



## USE SPECIFICATIONS:

Case Contents: 50 pieces/polybag, 2500 pcs/  
carton

Case Dimension: (L)19.8" x (W)15.8" x (H)13"

Case Weight: 19.8 lbs / 9 Kg

## PRODUCT SPECIFICATIONS:

- Fluid resistant and provides the wearer protection against large droplets, splashes, or sprays of bodily or other hazardous fluids. Protects the patient from the wearer's respiratory emissions
- Designed for a secure fit, the lightweight breathing mask has a comfortable to-wear, 3 ply construction and Comfortable tie on, extra-soft ear loops to eliminate pressure to the ears
- Non-woven material
- Disposable
- **2,800,000 in stock at Corona, CA**

**Price per mask  
(Pack 50)**

**\$0.10**

# SURGICAL GOWN – LEVEL 2



## PRODUCT SPECIFICATIONS:

- FDA/AAMI-2
- Materials: Nonwoven fabric 28G +Polyethylene 15G, weight 4
- Size: Medium, Large
- Breathable, dust-proof, waterproof, filter bacteria high densit
- Mainly for medical treatment, including medical institutions outpatient clinic, ward, laboratory, rescue protection, outdoor construction protection, agriculture and animal husbandry protection, pharmaceutical science protection, survey protec

FOB Corona

**\$1.95**

Quantity  
Available

**445,000**

## SPECIFICATIONS:

Size M: 1PC in a polybag, 300pcs put into one export carton

Size L: 1PC in a polybag, 230pcs put into one export carton

# MULTI-PURPOSE ALCOHOL WIPES



## PRODUCT SPECIFICATIONS:

- Wipes Material: Dispersible nonwoven
- Ingredients - 75% Ethanol alcohol, Benzalkonium Bromide, Silver Ions, Pure Water
- Sheet size: 5.0" x 7.0"

FOB Corona

Quantity Available

50-Pack

**\$1.50/pack**

**30,183**

pack: 40 per carton  
dimensions: 17x 13 x 8 inch  
weight: 21 lbs  
cartons per pallet at 48 x 40 x 73"

# MULTI-PURPOSE ANTIBACTERIAL WIPES



Back: 100 per carton  
dimensions: 14.2x 10 x 9 inch  
weight: 13.2 lbs  
cartons per pallet at 48 x 40 x 80"

## PRODUCT SPECIFICATIONS:

- Sheet quality: 50 gsm non-woven spunlace
- Ingredients - **Benzalkonium Chloride**, Aqua, Glycerin, A  
Barbadensis Leaf Juice, Decyl Glucoside
- Sheet size: 7.8" x 4.3"

**FOB Corona**      **\$0.40**

**Quantity  
Available**      **95,200**

# MULTI-PURPOSE ALCOHOL WIPES



## PRODUCT SPECIFICATIONS:

- Wipes Material: Dispersible nonwoven
- 40 GSM Wet Strength Paper
- MSDS Available upon request
- Ingredients - 75% Ethanol alcohol.
- Sheet Size: 7.8"x5.9"
- Private Label Production Available.

**FOB Corona      \$9.00**

**Quantity Available      10,000**

# Infrared Thermometer



## PRODUCT SPECIFICATIONS:

- *Size: 15.3x4.1x4.5cm*
- *Packing: plastic tray + manual + box, 100/ctn*
- *Meas.: 59.5x49x38cm*
- *N.W./G.W.: 12.5/13.5kgs*
- *Functions:*
  - \* *Forehead temperature range: 35°C ~ 42°C*
  - \* *Body temperature accuracy: ± 0.2°C*
  - \* *Memory: 10 times*
  - \* *Response Time: 1 Second*
  - \* *Temperature measuring distance: 1~2cm*
  - \* *Use environment: 16°C ~ 35°C*
- *Relative humidity: ≤ 85%*
- *Certificates: CE / ROHS / FCC*

**MOQ**

**1,000 units**

**FOB Corona**

**\$15.00**

**Times:**

Days Production Time + Air Freight

/color box, 100pcs/carton

on size : 62\*29\*16CM

# Portable UV-C sterilizer

## UV-C LED Sterilization Wand

Mini portable Lamp



### PRODUCT SPECIFICATIONS:

- Mini portable uv-c sterilizer wand
- size : 125\*30\*15mm
- weight : 30g
- battery : 400mA
- USB charging : Dc-5v
- charging time :1 hour
- disinfection Ultraviolet
- wavelength : 200~275nm
- working time : 5min (self-power outage)
- Certificates: CE Certificate / ROHS Certificate / FCC Certificate

**MOQ**

**10,000 units**

**AIR FREIGHT  
PRICE**

**\$11.00**

**Times:**

Days Production Time + Air Freight

Color box, 100pcs/carton  
Box size : 62\*29\*16CM

# Portable UV-C sterilizer Wand



## PRODUCT SPECIFICATIONS:

- UV-C portable sterilizer wand
- Working voltage : 5V USB charging
- Working current : 1A max
- Led : uv3535 6v 2w
- wavelength : 270-280nm
- single size : 357\*40\*35mm
- weight : 134g
- Colors: white / black / rose gold
- Certificates: CE Certificate / ROHS Certificate / FCC Certificate

**MOQ**

**10,000 units**

**AIR FREIGHT  
PRICE**

**\$17.00**

Times:

Days Production Time + Air Freight

pcs/color box, 100pcs/carton

Carton size : 42\*38\*45CM



## Product Diagram

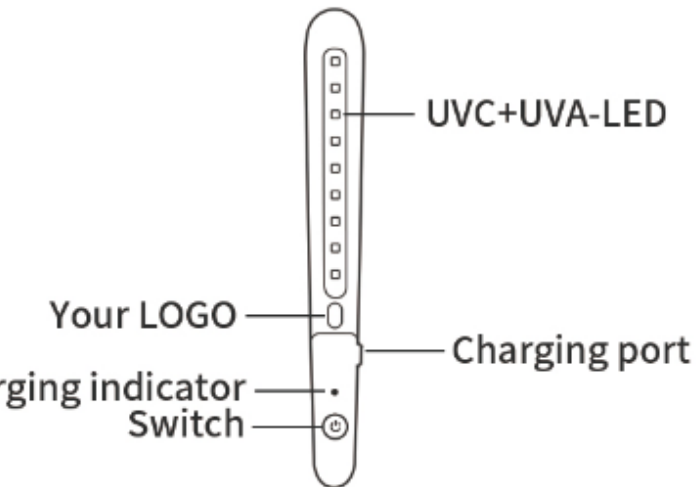

## Product Diagram

Product Name	UV Portable Sterilizer
Product Model	KJS-02
Working Voltage	USB 5V
Working Current	1A Max
LED	UV3535 6V 2W
Wavelength	270-280nm
Single Size	350×44×22mm
Weight	150g

## Steps for usage

1. Click the power button, the LED indicator light will turn on and the UV lamp will begin to work. Move the Sterilizer slowly, Keep the distance 5cm for 10-20 seconds and repeat it for two or three times with better effect.

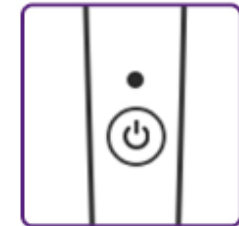

2. Click the power button again, the UV light will be turned off and stops working.

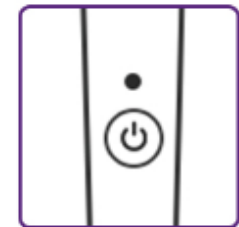

3. Insert the USB cable into the charging port, the red light will start charging, and the light turns to GREEN after full charge.

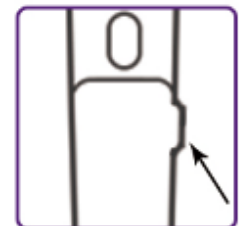

宅家养宠物  
不怕细菌玩偷袭  
House pets, Not afraid of  
bacteria playing sneak attacks

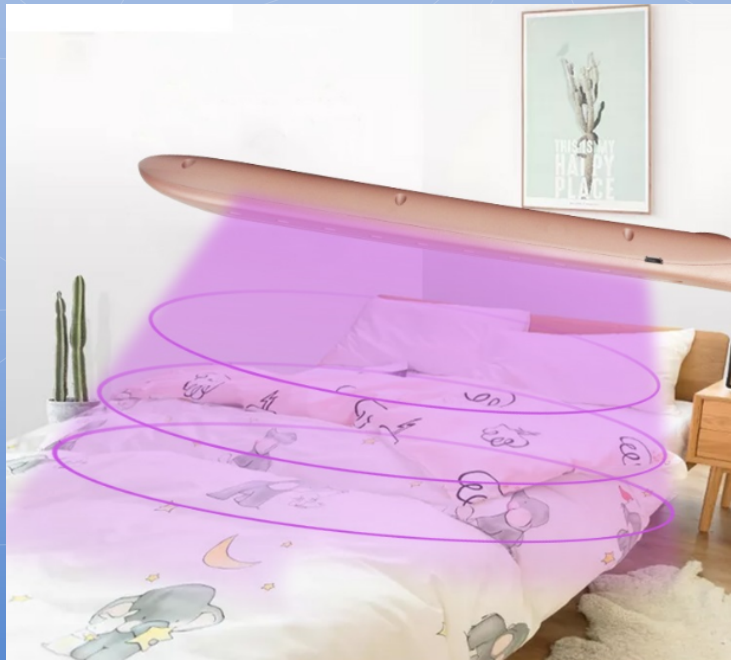

### 多功能UV消毒棒 Multifunctional UV disinfection stick



除臭  
Deodorant



紫外线杀菌  
UV disinfection



多物品消毒  
Multi-item  
disinfection





**THANK  
YOU**

[suraj@amrapur.com](mailto:suraj@amrapur.com) / 714356-9285